

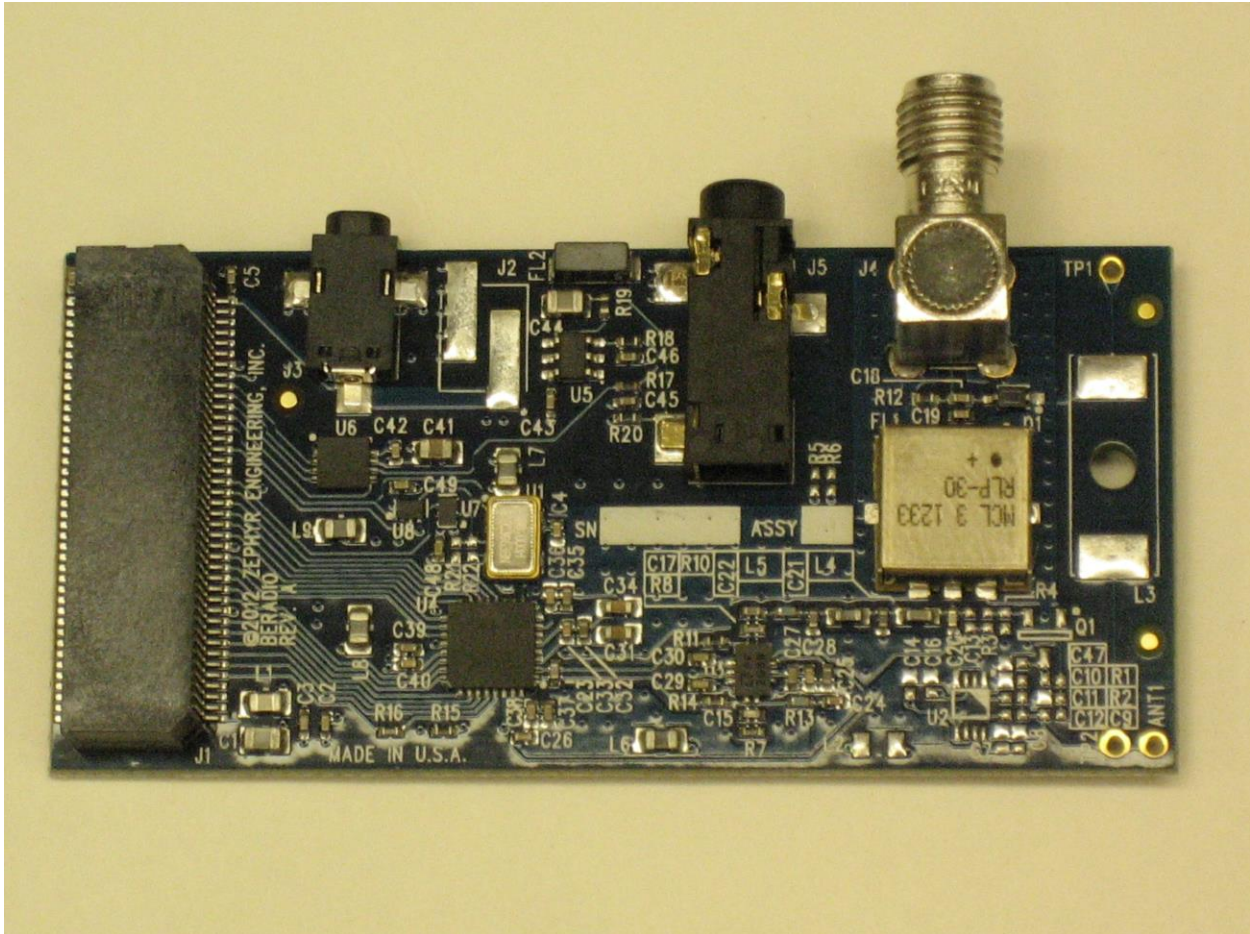

UDPSDR-HF1 Receiver Front-end



User's Manual
Version 1.1 – 16 September 2013



© Copyright 2013 Zephyr Engineering, Inc

1	<u>HARDWARE DESCRIPTION</u>	1
1.1	UDPSDR-HF1 CONNECTORS	1
1.1.1	UDPSDR-HF1 CONNECTORS	1
1.2	BEMICROSDK CONNECTORS, SWITCHES AND LEDS	3
1.2.1	BEMICROSDK CONNECTORS	3
1.2.2	BEMICROSDK LEDS	4
1.2.3	BEMICROSDK SWITCHES	6
2	<u>QUICK START GUIDE</u>	8
3	<u>DETAILED OPERATION</u>	8
3.1	STEP QS1 – DOWNLOAD AND INSTALL PROGRAMMING SOFTWARE	9
3.1.1	HOW TO DETERMINE WHAT PROGRAMMING SOFTWARE YOU NEED	9
3.1.2	DOWNLOAD AND INSTALL SOFTWARE	10
3.2	STEP QS2 – INSTALL USB BLASTER DRIVER	11
3.3	STEP QS3 – PROGRAM BEMICROSDK	12
3.3.1	SIDEBAR: BEMICROSDK CONFIGURATION FLASH ROM AND THE UFB	12
3.3.2	QS3A – CREATING A USER FLASH BLOCK FILE	13
3.3.3	QS3B – PROGRAMMING THE BEMICROSDK CONFIGURATION FLASH ROM	13
3.3.4	SIDEBAR: HOW THE BEMICROSDK GETS ITS MAC AND IP ADDRESSES	13
3.4	STEP QS4 – MAKE EXTERNAL CONNECTIONS	14
3.4.1	QS4B – ANTENNA	14
3.4.2	QS4C – ETHERNET DATA CONNECTION	14
3.4.3	QS4D – POWER	14
3.5	STEP QS5 – INSTALL AND RUN GUI SOFTWARE	15
3.5.1	HSDR	15
3.5.2	SDR#	16
3.5.3	POWERSDR	16
3.5.4	GNURADIO	17
4	<u>TROUBLESHOOTING</u>	18
4.1	PATH VARIABLE INCORRECTLY SET	18
4.2	JAVA NOT INSTALLED	18
4.3	NETWORK CABLE NOT PLUGGED IN	18
4.4	INCORRECT NETWORK ADDRESS ASSIGNMENTS	18
4.5	EXTIO.DLL NOT IN CORRECT DIRECTORY	19
5	<u>THEORY OF OPERATION</u>	19
5.1	UDPSDR-HF1 FRONT-END HARDWARE	19
5.2	UDPSDR-HF1 FPGA CODE	20
6	<u>SPECIFICATIONS</u>	21

1 Hardware Description

The following sections will help familiarize you with the setup and connections to your SDRstick™ HF1 SDR receiver.

1.1 UDPSDR-HF1 Connectors

See Figure 1 for UDPSDR-HF1 connector locations.

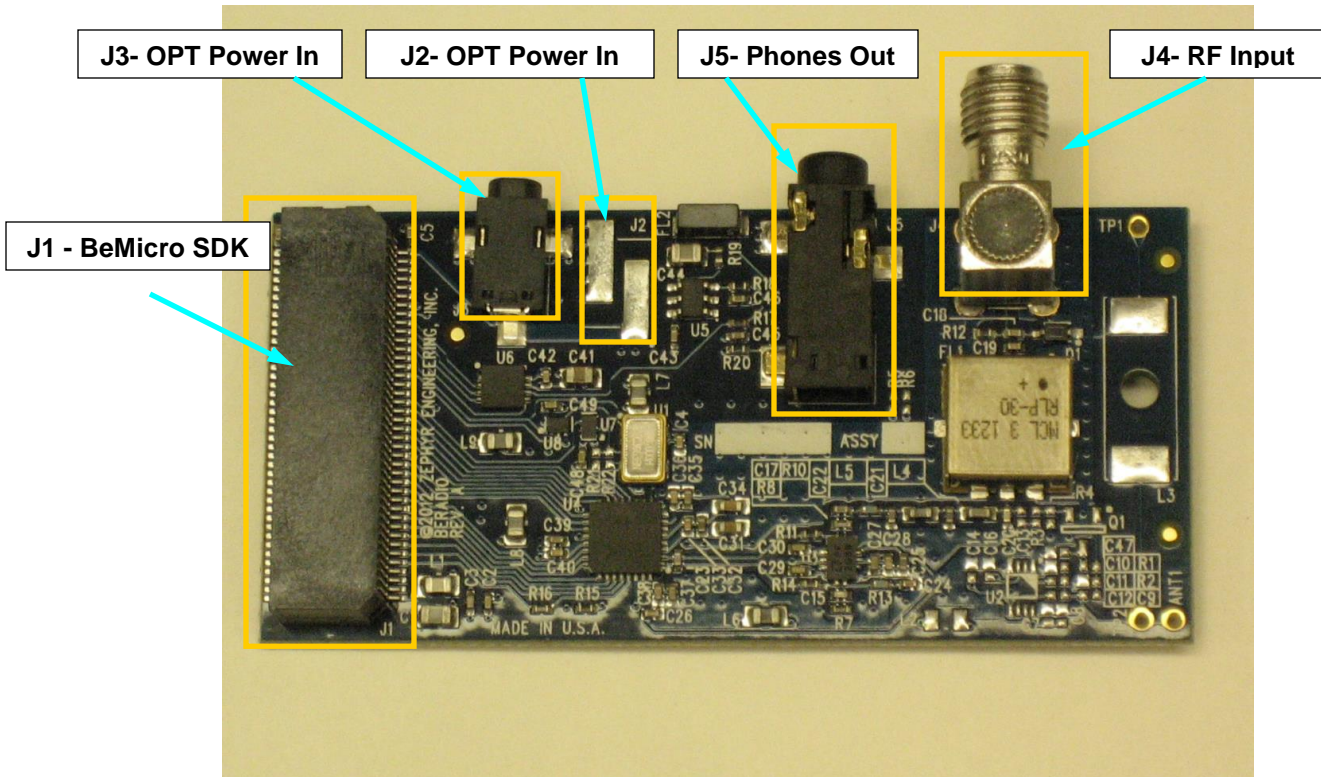

Figure 1 UDPSDR-HF1 Connectors

1.1.1 UDPSDR-HF1 Connectors

1.1.1.1 J1 – BeMicroSDK connector

The J1 80-pin dual-sided MEC-style edge connector plugs onto the gold-finger edge connector on the end of the BeMicroSDK. J1 connects digital data and power between the HF1 and the BeMicroSDK.

Note that the HF1 uses the BeMicroSDK pin assignments, not the MEC connector pin assignments from the Samtec data sheet. Pin 1 is marked on HF1 by a white dot. The pin 1 end of J1 is closest to capacitor C1. The BeMicroSDK pin 1 is clearly marked with a “1”. The correct HF1-to-BeMicroSDK pairing is shown in Figure 2.

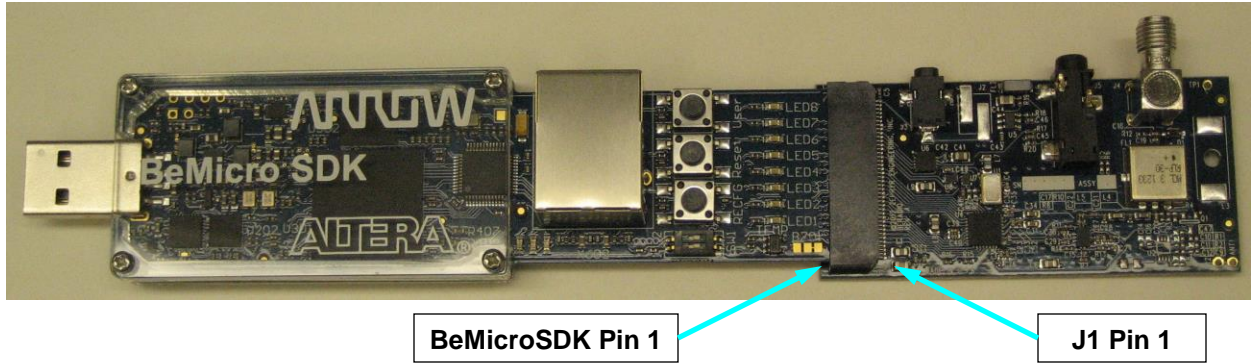

Figure 2 - The correct HF1-BeMicroSDK pairing

1.1.1.2 J3 and J2 - Power In

Power is supplied to the receiver in one of three ways (listed in most-to-least desirable order): USB, J3 or J2. The combination SDRstick™ HF1 requires 5VDC at about 400mA.

J3 and J2 are equivalent, since they are in parallel. J3 mates with a 2.35mm x .0.7mm barrel plug (CUI part #PP-012, Digi-Key part#CP-012-ND). J2 is provided for either a two-pin SMT header (TE part #3-647166-2, Digi-Key part #A113590-ND) or just pads for soldering wire leads. The center pin of J3 is positive. J2 pin 1 is positive and is marked with a white dot adjacent to the pad. See Figure 3 for details.

USB 2.0 or USB 3.0 ports can power the SDRstick™ HF1.

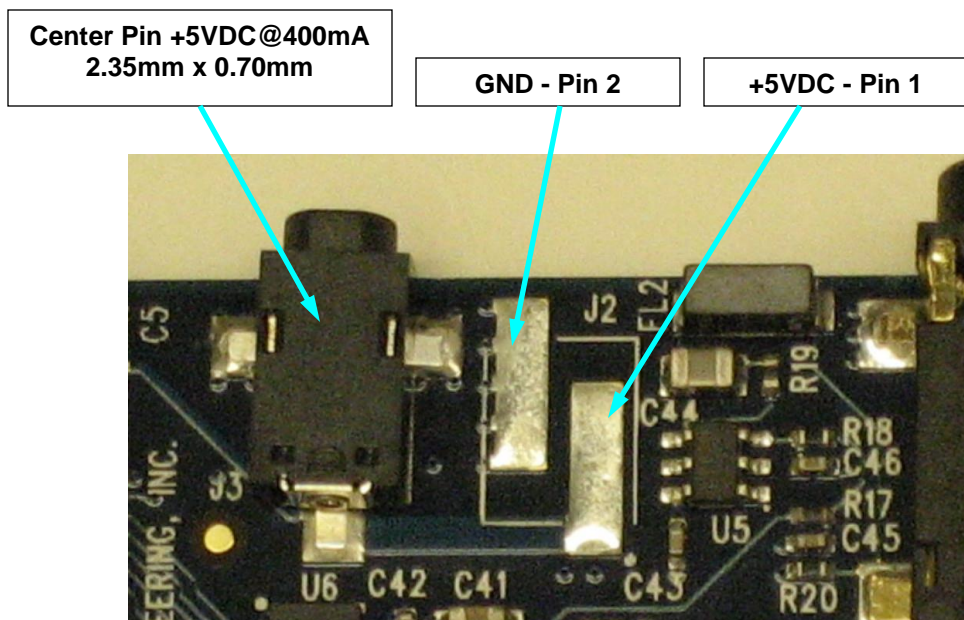

Figure 3 - Power Connector Detail

NOTE: In order to use the USB port for power, the Altera USB Blaster driver must be loaded onto the PC. The BeMicroSDK will not even turn on until this driver is properly installed. No driver is required to power the receiver from J3 or J2. See the Quick Start Guide.

WARNING: NEVER APPLY EXTERNAL POWER TO J3 or J2 WHILE PLUGGED INTO ANY USB PORT! THIS CAN DAMAGE YOUR USB PORT!

1.1.1.3 J4 – RF Input

The receiver RF input is connected to J4, a standard SMA jack. J4 may be connected directly to a 50-ohm antenna.

1.1.1.4 J5 – Phones Out (optional)

Plug headphones into J5, a 3.5mm stereo jack, which connects to the on-board audio DAC/headphone amplifier.

Note: The current FPGA code implementations send receive audio to the PC sound system rather than to J5. It is available as an option for the user.

1.2 BeMicroSDK Connectors, Switches and LEDs

See Figure 4 for BeMicroSDK connector, switch and LED locations.

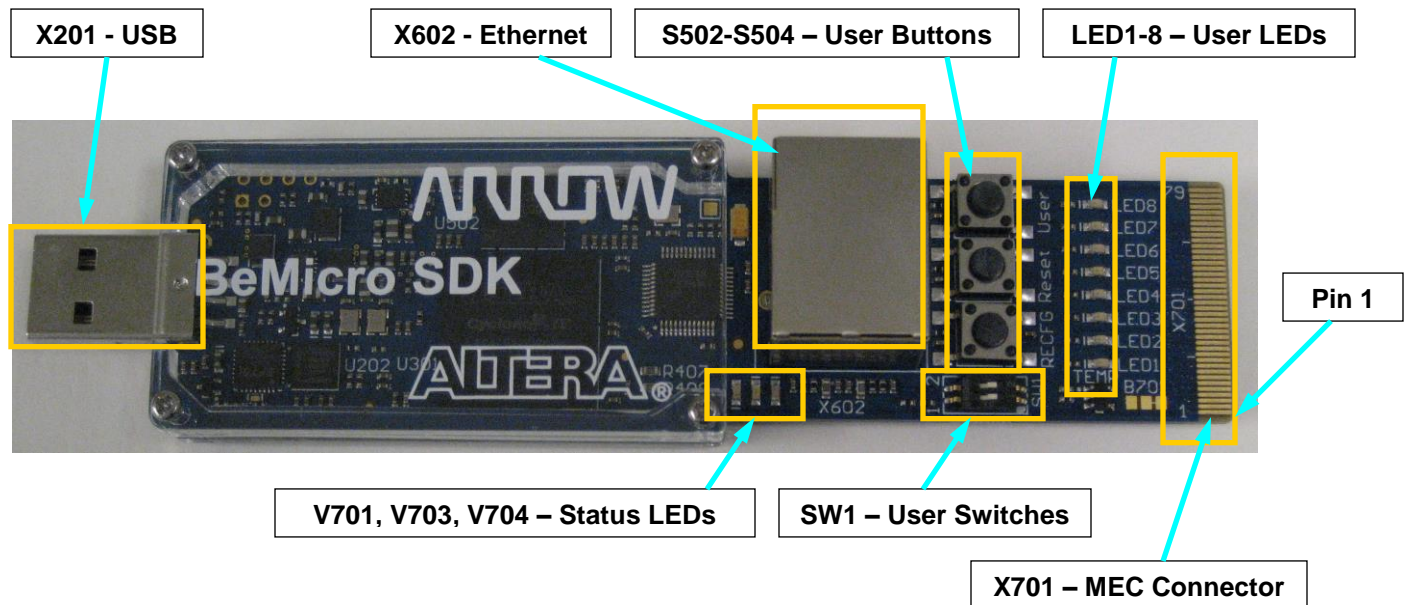

Figure 4 - BeMicroSDK Connectors, Switches and LEDs

1.2.1 BeMicroSDK Connectors

There are three connectors on the BeMicroSDK: one USB type A, one Ethernet RJ-45 and one 80-contact MEC edge connector.

1.2.1.1 USB Connector (X201)

The USB connector is used to program both the FPGA configuration RAM and the BeMicroSDK configuration flash memory. The BeMicroSDK appears to the host PC as an Altera Byte Blaster.

The USB connector can also be used to power the SDRstick™ HF1 when it is connected to a port that can supply sufficient power. USB 2.0 ports, USB 3.0 ports and powered hubs can power this 400mA load. A 5V well regulated power supply on J3 (or J2) can be used instead of the BeMicroSDK USB connector.

WARNING: NEVER APPLY EXTERNAL POWER TO J3/P1 WHILE PLUGGED INTO ANY USB PORT! THIS CAN DAMAGE YOUR USB PORT!

Note: In order to get the SDRstick™ HF1 to power up from a Windows PC USB port, the Altera Byte Blaster driver must be installed. A Byte Blaster driver is not needed for PCs running Linux in order to power up the SDRstick™ HF1.

1.2.1.2 Ethernet Connector (X602)

The Ethernet connector (X602) is a standard RJ-45 connector. The BeMicroSDK supports 10/100Mbps Ethernet, but 100Mbps is required for SDRstick™ HF1. This connection is used for the receive data stream to a host PC or network switch.

1.2.1.3 MEC Edge connector (X701)

The 80-contact MEC-style edge connector plugs into the UDPHDR-HF1 front-end board. All of the digital signals between the HF1 and the BeMicroSDK use this connector. Pin 1 is clearly marked on both the BeMicroSDK and the HF1 board.

Note: The pin numbering is different than that shown on the Samtec connector data sheet. Be sure to only plug the boards together in the orientation shown in Figure 2.

1.2.2 BeMicroSDK LEDs

There are two groups of LEDs on the BeMicroSDK: a group of 3 status LEDs below the RJ-45 connector and a group of 8 user LEDs alongside the MEC connector.

1.2.2.1 Status LEDs (V701, V703, V704)

The leftmost status LED (V701) is the green power indicator LED. The middle status LED (V703) is yellow, and is lit when the FPGA CONF_DONE pin goes high. The rightmost status LED (V704) is red and lights when pin 4 of the MEC connector is pulled low (PWREN2# asserted). Since HF1 never drives this pin low, this LED should never be lit. See Figure 5 for the status LED locations.

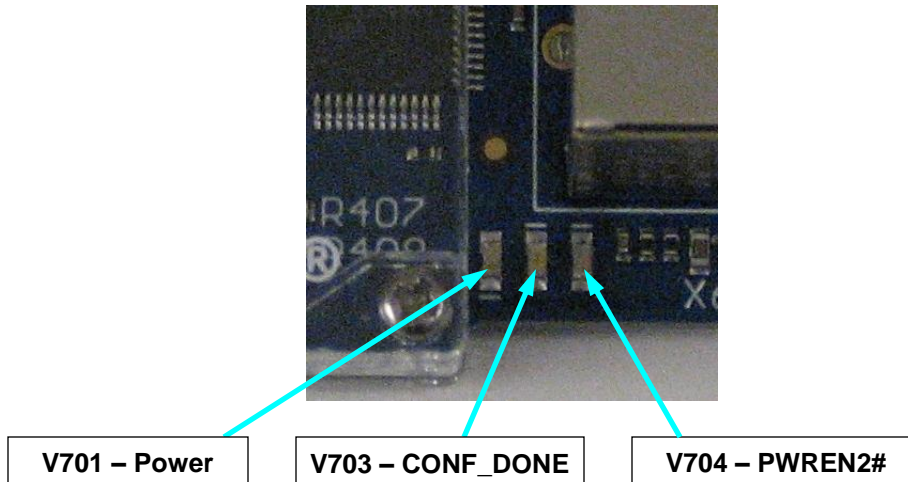

Figure 5 - BeMicroSDK Status LEDs

1.2.2.2 User LEDs (LED1 – LED8)

The eight user LEDs (LED1 – LED8) are under FPGA firmware control. Since the function of these LEDs is defined by the FPGA firmware, they can have any desired meaning. Some of the user LEDs are used to indicate some common conditions by the SDRstick™ firmware, shown in Table 1. See Figure 6 for user LED locations.

LED	Function
LED8 (top)	lit on A/D converter overload condition
LED7	lit on FIFO overflow (internal error condition)
LED6	off
LED5	off
LED4	off
LED3	off
LED2	Heartbeat: flashes ~ 1Hz from HF1 80MHz clock
LED1 (bottom)	Heartbeat: flashes ~ 1Hz from BeMicroSDK 50MHz clock

Table 1- UDPSDR-HF1 Firmware User LED Indicators

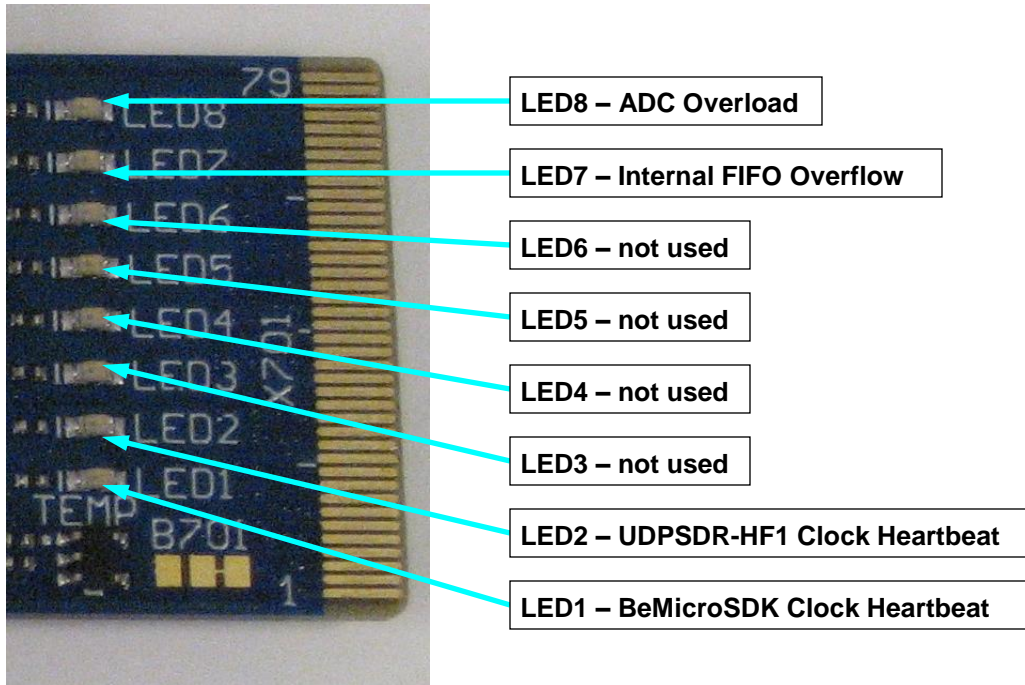

Figure 6- BeMicroSDK User LEDs

1.2.3 BeMicroSDK Switches

There are five switches on the BeMicroSDK: three push-button switches and two slide switches. See Figure 7 for switch locations.

1.2.3.1 Push-button Switches (S502 – S504)

The bottom push-button switch (S502), labeled “RECFG”, is used to force an FPGA reconfiguration. When this switch is pressed, the FPGA is reloaded from the on-board flash memory and restarts in the same manner as a power-on reset.

The middle push-button switch (S503), labeled “Reset”, is used to reset the FPGA logic and internal soft-core CPU. Note that this does not cause a reconfiguration; it merely restarts the FPGA logic from a known reset state.

The top push-button switch (S504), labeled “User”, can be read by the FPGA firmware. This switch is not currently used.

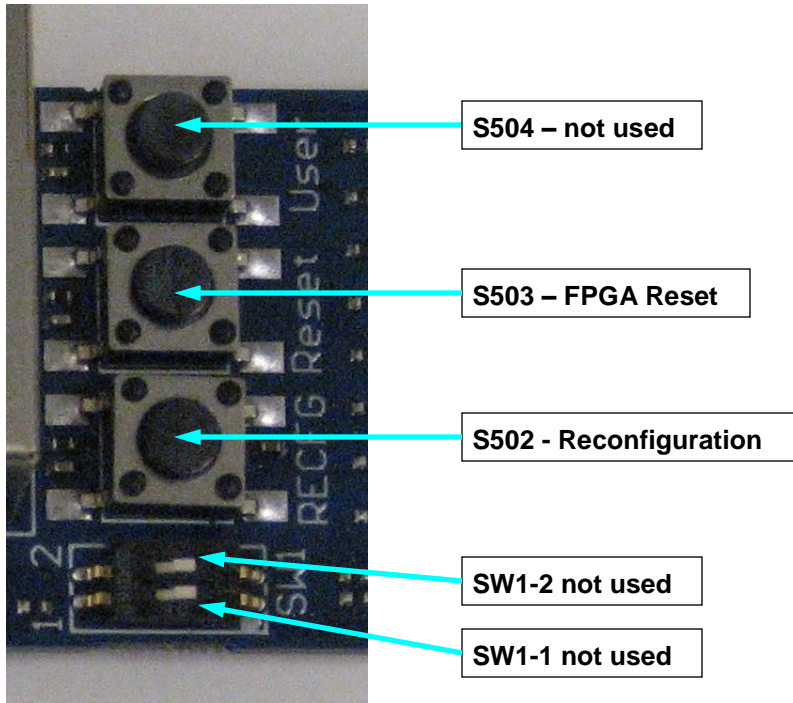

Figure 7 - BeMicroSDK Switches

1.2.3.2 Slide Switches (SW1-1, SW1-2)

The two slide switches, SW1-1 (bottom) and SW1-2 (top), can be read under FPGA firmware control. SW1-1 and SW1-2 are not currently used by the FPGA firmware.

2 Quick Start Guide

This quick start guide will lead you through the steps to get your SDRstick™ HF1 receiver operating. Please refer to Section 3 for in-depth information on each of these steps. If your BeMicroSDK came pre-programmed from the factory, you can skip steps QS1 and QS3.

- QS1. Download and install programming software
 - a. Download and install Altera Quartus II Web Edition
 - b. Download and install SDRstick™ Programmer
- QS2. Install Altera USB Blaster hardware driver (only needed for Windows)
 - a. Plug in BeMicroSDK and point to driver
 - b. Verify that power LED **V701** lights on BeMicroSDK
- QS3. Program BeMicroSDK
 - a. Use SDRstick™ Programmer to create User Flash Block FLASH file (make sure to choose an IP address on the same subnet as the PC, or use DHCP with a server that issues IP addresses on the same subnet)
 - b. Use SDRstick™ Programmer to program three FLASH files (two firmware and one user block) into BeMicroSDK flash memory
- QS4. Make external connections
 - a. Remove BeMicroSDK from computer
 - b. Install HF1 onto BeMicroSDK and connect antenna to **J4**
 - c. Connect Ethernet cable to host PC or network
 - d. Connect power and observe two flashing heartbeat LEDs on BeMicroSDK
- QS5. Install and Run GUI software on computer
 - a. One or more of GNURadio, HDSDR, SDR#, PowerSDR™ are options
 - b. ExtIO_SDRSTICK.dll must be placed into the same directory as the executable files – a separate copy is required for each GUI
 - c. For HDSDR and SDR#, observe that SDRstick discovery was successful
 - d. For PowerSDR™, configure for Hermes, 1 RX and 384K data rate
 - e. Receive audio is delivered via the PC's sound system

3 Detailed Operation

The sections of this chapter contain (or provide links to) detailed information on each step necessary to successfully set up the SDRstick™ HF1 Software Defined Receiver. It is beyond the scope of this document to cover operating-system specific procedures that are necessary to set up the receiver. It is assumed that the user is capable of performing the tasks in the following list. Please consult your PC and/or operating system documentation or use on-line searches to become comfortable with these procedures.

- Install applications
- Check system information and update hardware drivers
- Enable/disable both wired and wireless network ports
- Change PC IP address and network mask
- Enable and disable PC DHCP client
- Use console to check IP address and ping network devices
- Check/set environment variables using the system properties dialog box
- Navigate PC file system to copy and move files

3.1 Step QS1 – Download and Install Programming Software

The design and programming software for the BeMicroSDK is available for free download from the Internet. (Note that this software is different from the SDR GUI software that is used to operate the radio. We will cover that in section 3.5) There are four components to this support software. Which of the four components you need are determined by how you are going to use your HF1 receiver. See Table 2 for a quick summary of the support software components.

Support Software	Size	Source	Used To
Quartus II Web Edition Design Software	4.4GB	Altera.com	Write, modify, compile and program FPGA firmware into FPGA configuration SRAM
Quartus II Programmer	140MB	Altera.com	Program FPGA firmware into FPGA configuration SRAM
USB Blaster Driver	-	Included in Quartus II Web Edition and Quartus II Programmer	Enable BeMicroSDK USB power (Windows); required to program FPGA configuration SRAM or BeMicroSDK configuration flash memory
SDRstick™ Programmer	750KB	svn.SDRstick.com	Program BeMicroSDK configuration flash memory; create SDRstick™ User Block FLASH files

Table 2- Support Software Components

3.1.1 How to Determine What Programming Software You Need

To help you to determine what software to load, first we will explain a bit about how the FPGA works and then show you what each software program does.

3.1.1.1 SideBar: FPGA Configuration Technical Details

The FPGA stores its configuration (firmware) in internal static memory cells (SRAM). This internal FPGA memory is aptly called **configuration SRAM**. Since configuration SRAM is volatile, it must be initialized every time the FPGA is powered on. This can be done in two ways: from the USB port or from the BeMicroSDK on-board flash-programmable ROM. When power is first applied, dedicated circuitry inside the FPGA automatically loads the configuration SRAM from this configuration flash ROM, if it contains FPGA firmware. (Note that even if the ROM does contain a valid firmware load,

the FPGA configuration SRAM can be overwritten with a new firmware load from the USB port at any time.)

For the SDRstick™ HF1 receiver to work immediately on power-up, the BeMicroSDK configuration flash ROM must be programmed with the FPGA firmware load.

The Quartus II Web Edition software and the Quartus II Programmer software are both capable of writing directly to the FPGA configuration SRAM, but not to the BeMicroSDK configuration flash ROM. The SDRstick™ Programmer software was developed to write FPGA firmware loads to the BeMicroSDK configuration flash ROM, allowing the receiver to run immediately after power is applied.

The SDRstick™ Programmer uses components from the Quartus II Web Edition, as well as the USB Blaster Driver. Therefore, the USB Blaster Driver and the Quartus II Web Edition software must be installed in order to use SDRstick™ Programmer.

3.1.1.2 Determine Software Components

See table Table 3 to determine what software you will need to install, depending on how you want to configure your SDRstick™ HF1 receiver.

If your BeMicroSDK came pre-loaded from the factory and you are powering it from external power, you do not need to install any support software. If, at some point, you want to upgrade the firmware, you will need to install the necessary components from Table 3. You can do this at any time, as you need them.

To Do This	You Need This Support Software
Power HF1 from external power	none
Power HF1 from USB power (Linux)	none
Power HF1 from USB power (Windows)	USB Blaster Driver
Program or update FPGA firmware into BeMicroSDK configuration flash memory	Quartus II Web Edition, USB Blaster Driver, SDRstick™ Programmer
Program FPGA firmware into FPGA configuration SRAM for debugging (this is not common)	Quartus II Web Edition <u>or</u> Quartus II Programmer, USB Blaster Driver
Write custom FPGA firmware and program into FPGA configuration SRAM	Quartus II Web Edition, USB Blaster Driver
Write custom FPGA firmware and program into BeMicroSDK configuration flash memory	Quartus II Web Edition, USB Blaster Driver, SDRstick™ Programmer

Table 3 - Support Software Requirements

3.1.2 Download and Install Software

After you have determined what support software you need, go to <altera.com> and/or <svn.sdrstick.com> and download the installation files. If you need more detailed installation information, please download the **beradio lab** from the <beradio> section of

<svn.sdrstick.com>. Sections 2.4 and 2.5 of the lab walk you through the Quartus II Web Edition and USB Blaster driver installation.

3.1.2.1 Quartus II Web Edition

This is an extremely large download (about 4.4GB). Unless you have a fast connection to the Internet, it will take a long time to download. You may be able to save some download time by downloading individual files rather than the entire Quartus II Web Edition package. Click on the “Individual Files” tab to select individual components. You will need two components: **Quartus II Software (includes Nios II EDS and Cyclone II, Cyclone III, Cyclone IV device support)**. The combined size of these two components is only a bit over 2GB. After the download finishes, click on the file to install the software.

3.1.2.2 Quartus II Programmer

To load the Quartus II Programmer, you must go to the “Individual Files” tab and select **Quartus II Programmer and SignalTap II**. The size is about 140MB. After the download finishes, click on the file to install the software.

3.1.2.3 USB Blaster Driver

No download of the USB Blaster driver is required, as it is included with both the Quartus II Web Edition and Quartus II Programmer.

3.1.2.4 SDRstick™ Programmer

SDRstick™ Programmer is a Windows application that you can download from <svn.sdrstick.com>. Look in the <sdrstick-release> directory under <sdrstick-programmer>.

The SDRstick™ Programmer from <svn.sdrstick.com> is an executable windows installer file. Run the installer and follow the instructions. To un-install, run the installer again and select the uninstall option.

3.2 Step QS2 – Install USB Blaster Driver

The USB Blaster driver is included in the Quartus II Web Edition and Quartus II Programmer software. Once you have installed one of those two applications, plug the BeMicroSDK (without the HF1 attached) into a USB port. Cancel the windows installation of the driver, and go to the device manager. Find the “USB Blaster” entry in the table (it will have a yellow “!” next to it) and update the driver for it. Point the updater to the drivers, typically in the <C:\altera\13.0\quartus\drivers> for version 13.0. The system variable QUARTUS_ROOTDIR should contain the path to the directory containing the <drivers> directory.

Once the USB Blaster driver is properly installed, the power LED should light on the BeMicroSDK.

NOTE: The USB Blaster driver is not available as a separate download. If you intend to power your SDRstick™ from the USB port, you must download and install either the Quartus II Web Edition or the Quartus II Programmer software.

3.3 Step QS3 – Program BeMicroSDK

SDRstick™ Programmer is used for two functions. The first function is to create a User Flash Block file. The second function is to program FLASH format files into the BeMicroSDK configuration flash ROM. The SDRstick™ Programmer GUI is shown in Figure 8. The left pane is used to create a User Flash Block, and the right pane is used to program FLASH format files into the configuration flash ROM on the BeMicroSDK.

3.3.1 SideBar: BeMicroSDK Configuration flash ROM and the UFB

The BeMicroSDK flash ROM is divided up into three sections: FPGA fabric, NIOS soft-core CPU program code and the User Flash Block (UFB). Each of these sections is programmed from a FLASH format file. Two of these files provide the functionality of the FPGA and are supplied by the factory. The third file defines the contents of the UFB.

Each FLASH file contains a starting address and a length, and corresponds to one of the three sections of the ROM. Thus, the FLASH files may be specified in any order, and one, two or three at a time.

The UFB contains the user-defined MAC and IP addresses, and a flag bit that, when set, causes the BeMicroSDK to request an IP address from a DHCP server. The UFB can be expanded to include other user-defined parameters in the future.



Figure 8- SDRstick™ Programmer Window

3.3.2 QS3a – Creating a User Flash Block File

When SDRstick™ Programmer is opened, the **Create UFB** pane contains a default MAC address of **00:07:ed:fc:fd:fe**, a default IP address of **192.168.1.26** and the DHCP client turned off. Note that these are only the defaults that may be used to create a UFB FLASH file, and **do not reflect** the current BeMicroSDK network settings.

Enter the desired MAC address and either enter an IP address or check the **Use DHCP** box to enable the SDRstick™ DHCP client to request an IP address from a DHCP server.

Note: You must specify a unique MAC address on your network for each device (including SDRstick™ radios) even if you use DHCP to obtain an IP address.

Once you have set the network parameters, click **Generate**. You will be prompted for a path and a file name for the UFB FLASH file. For the network parameters to take effect, you must program this file into the BeMicroSDK configuration flash ROM using the **Program Flash** pane.

Note: A Java script generates the FLASH file. If file generation appears to complete normally but no FLASH file is created, check to make sure an up to date version of Java is installed on the PC.

3.3.3 QS3b – Programming the BeMicroSDK Configuration Flash ROM

Use the **Program Flash** pane to program FPGA firmware FLASH files and UFB FLASH file into the BeMicroSDK configuration flash ROM.

Click the **Add...** button to add files to the **Files to Program** window. Files can be added in any order. A section of the ROM will only be programmed if the corresponding FLASH file appears in this window, otherwise that section will be unaffected. You can update the UFB without updating the firmware, and vice-versa. Click the **Program** button to program the files into the configuration flash on the BeMicroSDK.

Note: Components of Quartus II Web Edition are used by SDRstick™ Programmer to program the BeMicroSDK configuration flash ROM. You should see several command windows containing scrolling text “pop up” and then close. The windows should appear long enough for you to read a few lines on each one. If nothing appears to happen, it is likely that your PATH variable is incorrectly set. Refer to PATH variable incorrectly set in section 4.1 for a solution.

3.3.4 SideBar: How the BeMicroSDK Gets Its MAC and IP Addresses

When the SDRstick™ is first powered on, it goes through a multi-step process to determine what MAC and IP address to use on the network.

To determine its MAC address, the SDRstick™ first looks to see if there is a valid UFB. If a valid UFB exists, the MAC address is obtained from the UFB. If no valid UFB exists

(i.e., it was not programmed into the configuration flash ROM), then the MAC address is set to **00:07:ed:01:23:45**. This is in the Altera block of IP addresses with the last three octets set to 0x012345.

Note: In order to use multiple SDRstick™ radios on the same network, you **MUST** set unique MAC addresses for each radio that are different from any other MAC address on the same network.

To determine its IP address, the SDRstick™ first looks to see if there is a valid UFB.

If there is a valid UFB, the SDRstick™ then looks to see if the DHCP client is enabled. If it is, then a DHCP request is broadcast. If an IP address is received from the DHCP server, that IP address is used. If the DHCP request is unsuccessful (for example, a timeout occurs) or the DHCP client is not enabled, the SDRstick™ uses the IP address from the UFB instead.

If there is no valid UFB, the SDRstick™ broadcasts a DHCP request. If an IP address is received from the DHCP server, that IP address is used. If the DHCP request is unsuccessful (for example, a timeout occurs), the SDRstick™ uses the default IP address of **192.168.1.25**.

3.4 Step QS4 – Make External Connections

The SDRstick™ requires three external connections to function: antenna, Ethernet data connection and power input.

3.4.1 QS4b – Antenna

Connect an antenna to the J4 SMA connector. Note that there is no bandpass filtering at the receiver front-end. Excessive voltage at the antenna jack can damage the receiver. Any voltage above about 3V p-p may damage the input circuitry.

3.4.2 QS4c – Ethernet Data Connection

Connect the BeMicroSDK Ethernet port either directly to a PC network port or to a LAN through a 100Mbps switch. Even though the port hardware supports 10Mbps and 100Mbps, a 100Mbps connection is required for proper operation. (Even at the lowest sample rate, 10Mbps Ethernet has insufficient bandwidth to support this receiver.)

3.4.3 QS4d – Power

Either plug the BeMicroSDK into a USB 2.0 or USB 3.0 port or connect a power supply to J3. The BeMicroSDK and UDPSDR-HF1 combination requires about 400mA at 5VDC to operate properly. While the best way to supply power is through connector J3, you may also supply power through the USB connector.

Since the BeMicroSDK negotiates for power over the USB port before it turns on, you cannot use a USB charger to power SDRstick™ HF1 regardless of its current capacity.

Note: Clean power is especially important given the high sensitivity of this receiver. USB power is not noted for its purity. If you experience excessive receiver noise while on USB power, especially at lower frequencies, consider using a well-filtered external power supply instead.

WARNING: NEVER APPLY EXTERNAL POWER TO J3/P1 WHILE PLUGGED INTO ANY USB PORT! THIS CAN DAMAGE YOUR USB PORT!

3.5 Step QS5 – Install and Run GUI Software

Tutorials on SDR GUI software are beyond the scope of this manual, but here are some quick links and tips for setting up four common but powerful programs that will work with your SDRstick™ HF1 receiver.

3.5.1 HSDR

High Definition Software Defined Radio, or HSDR, is a freeware SDR program for Windows 2000 through Windows 8. HSDR is written by Mario Taebel, DG0JBJ, and is an advanced version of Winrad. This is an excellent SDR GUI, and may be downloaded from the HSDR web site < <http://www.hdsdr.de/>>

The HSDR download is an executable installer for Windows. Simply download it to a directory on your local drive and run it to install the software.

After you have installed HSDR, you must place a copy of ExtIO_SDRSTICK.dll in the directory that HSDR runs. The latest version of this file can be found on the web at <svn.sdrstick.com> in the <sdrstick-release/software> directory.

If you have followed all of the above steps, when you run HSDR, an SDRstick™ network discovery dialog box will pop up showing the IP address of the SDRstick™ receiver that HSDR found on the network. Click **OK**, and the HSDR main screen appears. Simply click the **Start** button and you are on the air!

3.5.1.1 HSDR Tips

Here are a few tips for using HSDR with SDRstick™ HF1.

3.5.1.1.1 *Soundcard Selection*

If you are having receiver audio issues, click on the **Soundcard [F5]** button. You can then select one of several options, in case your PC has more than one audio output device. Also note that there is a **Mute** button in the left center of the cluster of blue buttons above the date display. HSDR saves the setting of **Mute** from run to run, so if you had the receiver muted when you shut HSDR down, it will still be muted when you launch HSDR again.

3.5.1.1.2 *Bandwidth Selection*

The SDRstick™ firmware gives you two options for input sampling rate: 1.25Msps and 384Ksps. To change the input sampling rate, click the **Bandwidth [F6]** button. At the

bottom of the left column, you will see a dialog box. Click on the small down-arrow and you will be presented with two selections, “384000” (384Ksps) and “1250000” (1.25Msps).

There are two reasons that you might want to select the lower sampling rate. The lower sampling rate requires less CPU resources, so you might want to choose a lower rate if you PC is slower or older. Another reason to choose a lower sampling rate is to reduce the network load. The 1.25Msps sample rate will consume about 50% of the entire 100Mbps network bandwidth, or about 50Mbps. This will not work over most WiFi connections unless you reduce the sample rate. At 384Ksps, the data rate is about 15Mbps, which may be transportable over most 802.11g or 802.11n WiFi networks, but not over 802.11b networks.

3.5.2 SDR#

SDR# (read SDR Sharp) is a high performance SDR application for Windows written in C#. It is a fully featured SDR, and is available for download here:

<<http://sdrsharp.com/>>

The SDR# download is a zip archive, rather than an executable installer for Windows. Simply download it to a directory on your local drive and unzip the files.

After you have unzipped the files, you must place a copy of ExtIO_SDRSTICK.dll in the same directory. The latest version of this file can be found on the web at <svn.sdrstick.com> in the <sdrstick-release/software> directory.

If you have followed the above steps, when you run SDR#, an SDRstick™ network discovery dialog box will pop up showing the IP address of the SDRstick™ receiver that SDR# found on the network. Click **OK**, and the SDR# main screen appears. Simply click the **Play** button and you are on the air!

3.5.3 PowerSDR

PowerSDR is fully featured SDR software for Windows, and is available for download from the openHPSDR downloads page here: <<http://openhpsdr.org/download.php>>.

Scroll down to near the bottom, under the Windows section, and look for

PowerSDR_mRX_v3.1.5.0_Setup or a similar revision.

The PowerSDR download is an executable installer for Windows. Simply download it to a directory on your local drive and run it to install the software.

PowerSDR does not require ExtIO_SDRSTICK.dll.

After you launch PowerSDR and before you click the **Power** button for the first time, you must click on the Setup tab and configure your hardware. Under the <General><Hardware Config> tab, select **HERMES** as your Radio Model, and click the **1-receiver** check box. Under the <General><Options> tab, select HIGH as the

Process Priority. Under the <Audio><Primary> tab, select 384000 in the **Sample Rate** box. Under the <Audio><VAC1> tab, click the **Enable VAC 1** check box.

Close the Setup window and click the **Power** button and you are on the air! If you go back to the Setup window now, under the <General><Hardware Config> tab, you will see your SDRstick™ IP and MAC addresses displayed in the lower right corner of the window, under **Hermes Address**.

3.5.4 GNURadio

GNURadio is an open-source software development toolkit for Linux and Windows used to implement software-defined radios.

These instructions are for GNURadio version 3.6.5.1 under Ubuntu Linux 12.04LTS. Other versions are available; the installation procedure may be different.

3.5.4.1 GNURadio Installation

Point your browser to the GNURadio web page below and follow the instructions in the section **Using the build-gnuradio script**.

<http://gnuradio.org/redmine/projects/gnuradio/wiki/InstallingGR#Using-the-build-gnuradio-script>

3.5.4.2 SDRstick™ Source Block Installation

Point your browser to the SDRstick™ web SVN server here: <<http://svn.sdrstick.com>> and download the file **gr-sdrstick-sourceblock.tar.gz** from the <**sdrstick-release/gnuradio/sourceblock**> directory. Extract the files from this gzip archive into a directory of your choice. Follow the directions in the extracted **Readme.txt** file to install the GNURadio SDRstick™ sourceblock and an example GRC flowgraph. The contents of the Readme.txt file are reproduced in Figure 9 for your convenience.

```
- Uncompress in directory of your choice.  
- cd gr-sdrstick  
- mkdir build  
- cd build  
- cmake ../  
- make  
- sudo make install  
- sudo ldconfig
```

Figure 9 - GNURadio Sourceblock Installation Readme.txt File

Start gnuradio-companion and open the example flowgraph using <file><open>. The flowgraph is named **sdrstick_am_rx.grc** and is located in the **gr-sdrstick/apps** directory.

4 Troubleshooting

Some of the more common problems and their solutions are outlined in the following sections. If you are still stuck after reading through this chapter, please log onto the SDRstick™ Yahoo group and ask for help.

To subscribe to the group, go to <http://groups.yahoo.com/groups/SDRstick>

4.1 PATH variable incorrectly set

Symptom: SDRstick™ Programmer appears to run, but the several windows just momentarily flash up on the screen and the BeMicroSDK does not get programmed.

Cause: SDRstick™ Programmer cannot find the software components it needs to program the BeMicroSDK files.

Solution: If Quartus II Web Edition is not installed, you must install it. If Quartus II Web Edition is already installed, you need to add a string to your PATH variable that points to the installed directory, typically **C:\altera\13.0\quartus\bin**, where **13.0** is replaced by whatever version number you have installed.

4.2 Java not installed

Symptom: SDRstick™ Programmer does not create a FLASH file when you click the **Generate** button.

Cause: Java is not installed.

Solution: Install a current version of Java.

4.3 Network cable not plugged in

Symptom: SDRstick™ discovery fails.

Cause: Ethernet cable not connected between SDRstick™ and PC or network switch.

Solution: Make sure that there is an Ethernet connection between the SDRstick™ and the PC. Verify the connection by Pinging the SDRstick™ from the PC. Remember that the data flows through the Ethernet port, not the USB port.

4.4 Incorrect network address assignments

Symptom: SDRstick™ discovery may or may not succeed, but communication fails and the receiver is unresponsive.

Cause: The PC and the SDRstick™ are on different subnets.

Solution: Either reprogram the SDRstick™ to an IP address within the same subnet as the PC, or change the IP address of the PC so that it is within the same subnet as the

SDRstick™. Since SDRstick™ discovery is a broadcast, it may succeed even though it is on a subnet that is unreachable by the PC. Make sure that all MAC and IP addresses on the entire network are unique, and that all IP address bits with a “1” in the network mask are the same. For example, if your PC is set to IP address 192.169.1.10 with a net mask of 255.255.255.0, then you can set your SDRstick™ IP address to 192.168.1.xx, where xx=a number from 1 to 254, excluding 10 (which is already used by your PC).

4.5 ExtIO.dll not in correct directory

Symptom: HSDR and/or SDR# start right up, but no SDRstick™ is found.

Cause: ExtIO_SDRSTICK.dll has not been copied into the run directory.

Solution: The ExtIO_SDRSTICK.dll file is required for HSDR and SDR# to work with SDRstick™. Place a copy in the same directory as the executable file is located.

5 Theory of Operation

The next two sections describe the design of the UDPSDR-HF1 in very basic terms.

5.1 UDPSDR-HF1 Front-End Hardware

The UDPSDR-HF1 PCB block diagram is shown in Figure 10. The signal flow is straightforward, with the RF signal passing through the LPF, anti-alias filter and ADC driver before being sampled by the ADC.

The ADC can be clocked either by the on-board 80MHz clock oscillator or a CLK_IN signal from the FPGA on the BeMicroSDK.

The audio DAC and headphone driver are not used by the current firmware, as receive audio is sent to the PC sound system.

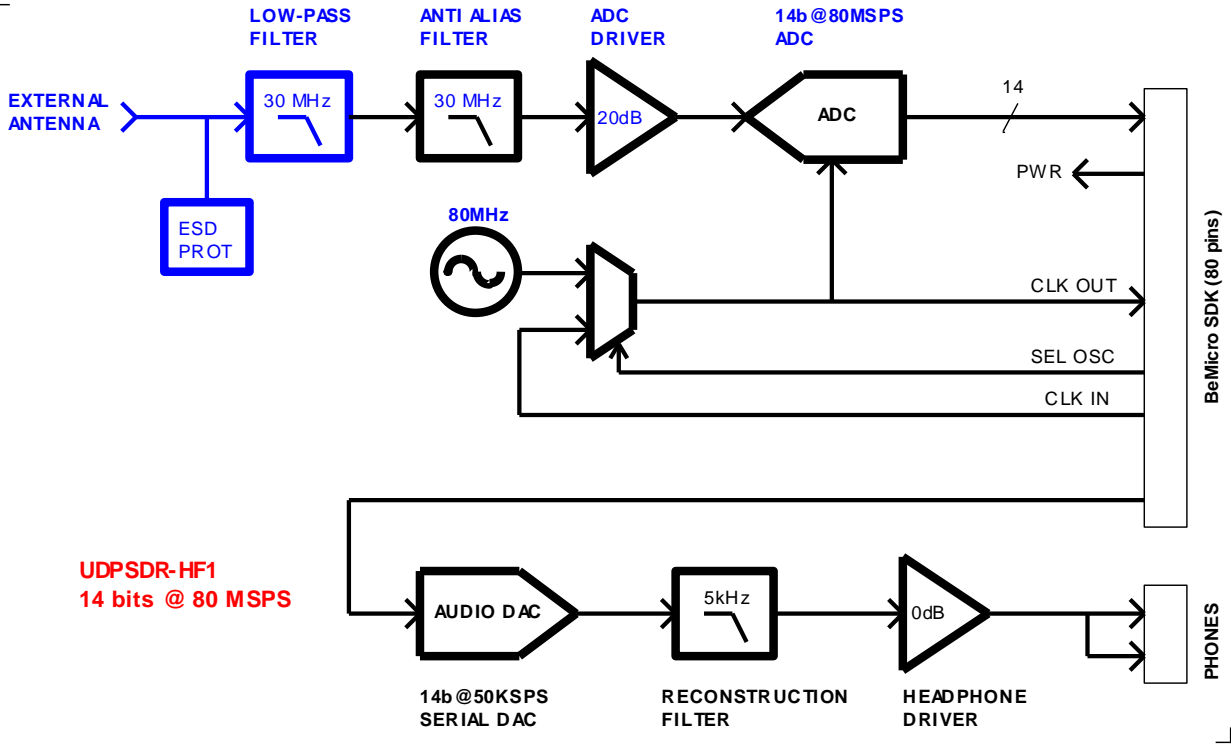

Figure 10 - UDPSDR-HF1 Hardware Block Diagram

5.2 UPDSDR-HF1 FPGA Code

The UDPSDR-HF1 simplified FPGA block diagram is shown in Figure 11. This very basic flow shows the Numerically Controlled Oscillator and the two multipliers that serve as a down-converter, followed by two decimating filters. The I/Q data is buffered by a FIFO and sent to the Ethernet MAC for transmission as UDP packets on the network.

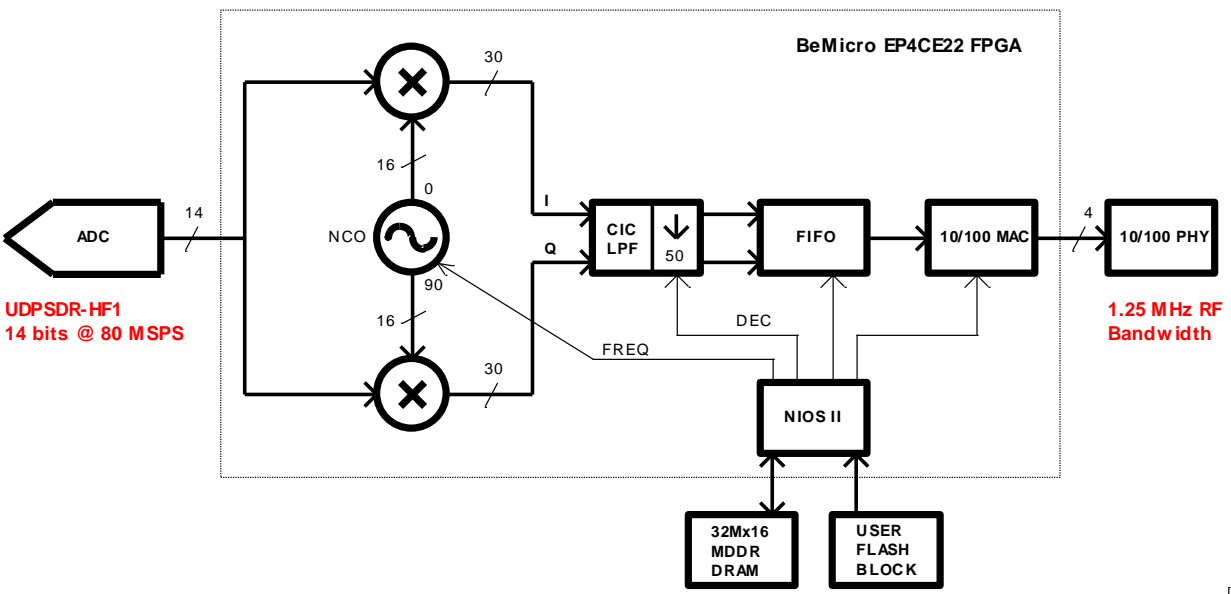

Figure 11 - UDPSDR-HF1 Simplified FPGA Firmware Block Diagram

An internal NIOS soft-core CPU controls all of the processes and the data flow. The NIOS CPU also controls the boot loader functions and external flash memory programming operations, not shown.

6 Specifications

- Frequency Range: 100kHz to 30MHz, Digital Direct Sampling (DDS)
- Input impedance: 50 ohms
- RF input clipping level (typical): -7dBm
- Maximum Display Bandwidth: 1.25MHz
- Sampling Width and Rate: 14bits @ 80Msps
- MDS: -118dBm @ 14MHz (500Hz BW) for 3dB noise floor increase
- Antenna connection: standard SMA
- Power consumption: +5VDC @ 400mA (including BeMicroSDK)
- Dimensions, UDPSDR-HF1: 31mm x 65mm (1.2"W x 2.6"L)
- Dimensions, including BeMicroSDK: 33mm x 185mm (1.3"W x 7.3"L)